



CRUSHER BUCKET

CBE 20

CRUSHER BUCKET WITH ROTOR SYSTEM FOR EXCAVATORS

Excavator weight between 10 and 18 tonne. Designed to reduce the volume of aggregates directly on site.



FEATURES

STANDARD EQUIPMENT ON NZ MODELS

Direct drive hydraulic piston motor
1485mm wide bucket
Anti-wear surface teeth

Rotor system with teeth driven by hydraulic piston motors in direct drive enables crushing of any material

Lightweight structure
Won't transmit vibrations to the prime mover or operator.

Easy loading
Wide mouth, shaped as standard bucket. Can operate with back or front loading.

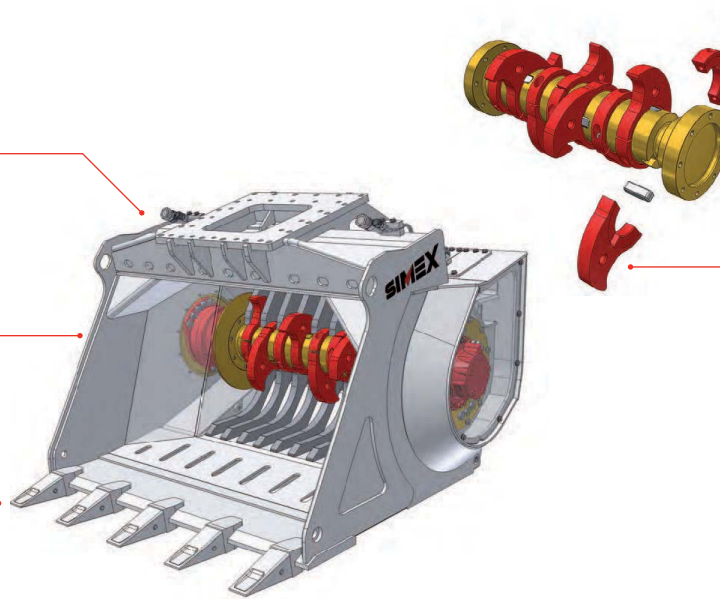

Simple, quick teeth replacement

Increased protection and working life
teeth with large anti-wear surface.

CBE 20	Mouth width (mm)	Total width (mm)	Rotor width (mm)	Bucket capacity (SAE) (m ³)	Cutting force (kN)	No. of teeth	Bucket weight empty* (kg)	Oil flow (L/min)	Oil pressure (BAR)
Crusher Bucket with Rotor System	1250	1485	735	60	95	5	1320	100 - 190	350 - 230

*Without mounting bracket

